

Precise™ Mirror Mounts

- **L-shaped back plate maximizes clear aperture at 45 degrees**
- **Kinematic design for 25.4 mm round mirrors**
- **Cutaway design**
- **100 threads per Inch adjusters with hex key option**
- **Allen key adjusters**
- **Positive nylon tipped mirror locking screw**



These popular 1 inch Mirror Mounts are designed to accept round, front surface mirrors or beamsplitters up to 25.4 mm diameter. Holes provided in the back plate are designed for universal mounting on almost all hardware. The M4 (8-32) clearance mounting holes are positioned directly below the center of the mirror mounted.

These mounts can be bottom mounted on a Half-inch Post, or StablePillar™ or one of two riser blocks described in the side bar. Alternatively, they can be side mounted on a rod system carrier. Mirrors are retained in the mount by two delrin inserts and a nylon tipped set screw. A range of adapters are available for mounting smaller mirrors and optics.

An OEM version of the Precise 1 inch Mirror Mount is also available. This is exactly the same as the standard mount except the knurled stainless adjusters are replaced with more compact hex adjusters.

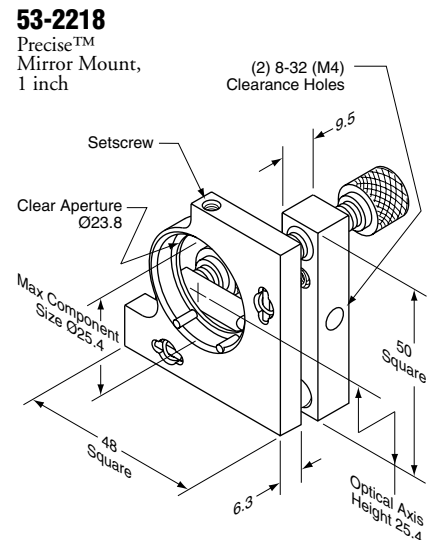

Specifications

Angular Adjustment Range: $\pm 10^\circ$
Pivot Arm Length: 38 mm
Actuator Thread Pitch: 100 TPI
Angular Resolution or Sensitivity: 3.8 arcsec (0.001°)
Clear Aperture: 23.8 mm
Max Component Dia: 25.4 mm
Optical Center Height: 25.4 mm

Precise™ Mirror Mounts

Catalog Number	Description	Max Optic Dia. (mm)	Optical Axis Height (mm)	Price US
53-2218	Precise™ Mirror Mount, 1 inch	25.4	25.4	\$79.00
53-2630	Precise™ Mirror Mount, 1 inch OEM	25.4	25.4	\$79.00

Optics

Lenses & Microscope Components

Coatings

Mirrors & Beamsplitters

Prisms & Polarizers

Filters

Pinholes

Opto-mechanics

Rails

Mounting Hardware

Mirror & Component Mounts

Manual Micro Positioners

Motorized Positioners

Optical Instruments

Microscopes

Light Sources